

IB444 1/4"-2"

Bronze Globe Valve
300 SWP - 1000 WOG †
Special Hardened S.S. Seat Ring and Disc
Union Bonnet • Threaded Ends
Conforms to: MSS SP-80

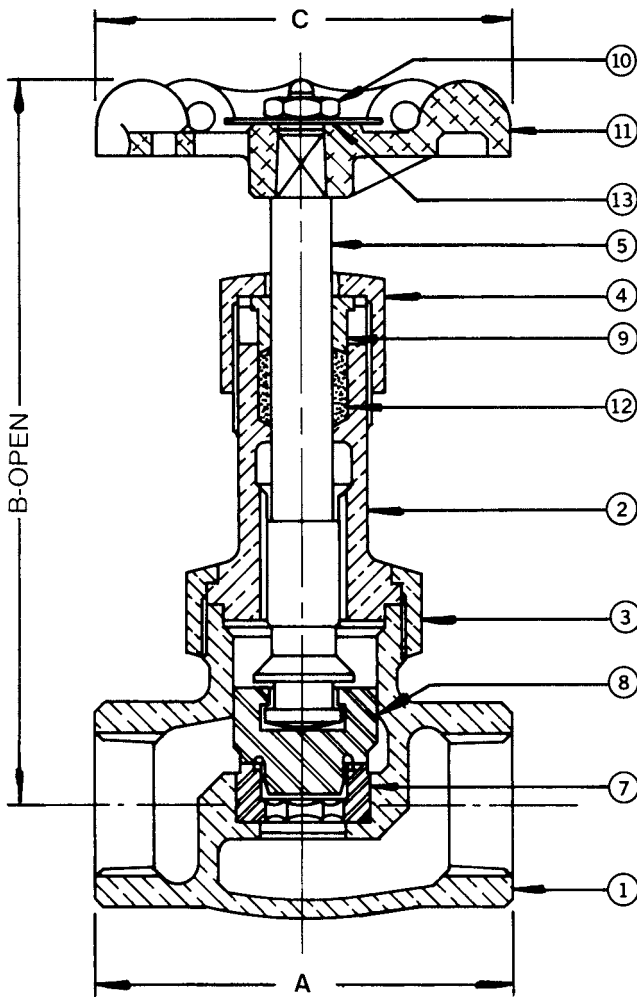

Note: Not intended for use in potable water.

MATERIAL LIST			
No.	PART	MATERIAL	SPECIFICATION
1	Body	Bronze	ASTM B61
2	Bonnet	Bronze	ASTM B61
3	Union Bonnet Nut	Bronze	ASTM B61
4	Packing Nut	Bronze	ASTM B62
5	Stem	Bronze	ASTM B61
6 ¹	Disc Ring	Bronze	ASTM B62
7	Seat Ring	St. Steel	ASTM A 276, TY. 420
8	Disc	St. Steel	ASTM A 276, TY. 420
9	Gland	Brass	ASTM B16
10	Handwheel Nut	Brass	ASTM B16
11	Handwheel	Mall. Iron	Commercial
12	Packing	Graphite	
13	Name Plate	Sh. Alum.	Commercial

¹ Not shown- used on 1 1/4" and larger valves only.

- This valve has flat seat shutoff with plug type disc for throttling action and replaceable seat and disc.

DIMENSIONS - INCHES/MILLIMETERS					
Units	Size	A	B	C	C _v
Inches mm	1/4	2.13 54	4.38 111	2.00 51	1.16
Inches mm	3/8	2.38 60	4.44 113	2.00 51	2.21
Inches mm	1/2	2.75 70	4.50 114	2.25 57	3.64
Inches mm	3/4	3.19 81	5.13 130	2.75 70	6.65
Inches mm	1	3.63 92	5.38 137	3.25 83	11.10
Inches mm	1 1/4	4.13 105	6.25 159	3.75 95	20.00
Inches mm	1 1/2	4.75 121	7.38 187	4.25 108	28.00
Inches mm	2	5.13 130	8.38 213	4.75 121	48.00

† Non-Shock

The information presented on this sheet is correct at the time of publication. Hammond Valve reserves the right to change design, and/or material specifications without notice. For the Installation, Operation and Maintenance Manual (IOM) see the Technical/Service Information section on our website. For the most current information access www.hammondvalve.com Hammond Valve is a registered trade mark of Milwaukee Valve Company.